

C2148 – 2000 lb Cube Ice Machine

Prodigy® Modular Cube Ice Maker



Shown on BH1600SS bin.

Features

Prodigy® cubers use **significantly less energy and water** than other cube ice machines, exceeding Federal energy efficiency regulations.

AutoAlert™ indicator lights constantly communicate about operating status and actually signal your staff when it's time to descale, sanitize, and more—making upkeep practically foolproof.

The patented **WaterSense adaptive purge control** delivers maximum reliability by reducing scale buildup for a longer time between cleanings.

Preventative maintenance is simpler than ever with easily-removed panels allowing clear access to internal components and a diagnostic code display insuring the right fix the first time. Reusable air filter is easily removable from the outside.

All external panel components are crafted for **optimal aesthetic appeal** through superior fit and finish.

An optional **advanced feature Smart-Board™** provides NAFEM data protocol and additional operational data that can be displayed on-screen or transmitted remotely, resulting in early alert and fast diagnosis of operating issues.

An optional **Vari-Smart™ ultrasonic ice level control** sensor allows you flexibility to program ice levels, for up to 7 days, keeping just the right amount of freshly made ice in the bin.

24 Hour Volume Production

Remote			Water Cooled		
70°F/21°C 50°F/10°C lb/kg	Air Water	AHRI 90°F/32°C 70°F/21°C lb/kg	70°F/21°C 50°F/10°C lb/kg	Air Water	AHRI 90°F/32°C 70°F/21°C lb/kg
2248/1022		1849/840	2091/950		1804/820



Modular Bin Options

* Stainless Steel with Galvanized Back & Bottom.

Model Number	Dimensions W" x D" x H"	AHRI Certified Bin Capacity lb/kg	Application Capacity lb/kg	Finish	Ship Weight lb/kg
BH1600BB	60 x 34 x 62	1375/624	1755/796	SS w/ GBB*	370/168
BH1600SS	60 x 34 x 62	1375/624	1755/796	SS	370/168



Bin: BH1600SS

Cube Ice



Small Cube
3/8" x 3/8" x 3/8"
(2.22 x 2.22 x .95 cm)

Medium Cube
7/8" x 7/8" x 7/8"
(2.22 x 2.22 x 2.22 cm)

Common ice form, ideal for mixed drinks.

Warranty

- 3 years parts and labor on all components.
- 5 years parts and labor on the evaporator.
- 5 years parts on the compressor and condenser.

Warranty valid in North, South & Central America. Contact factory for warranty in other regions.

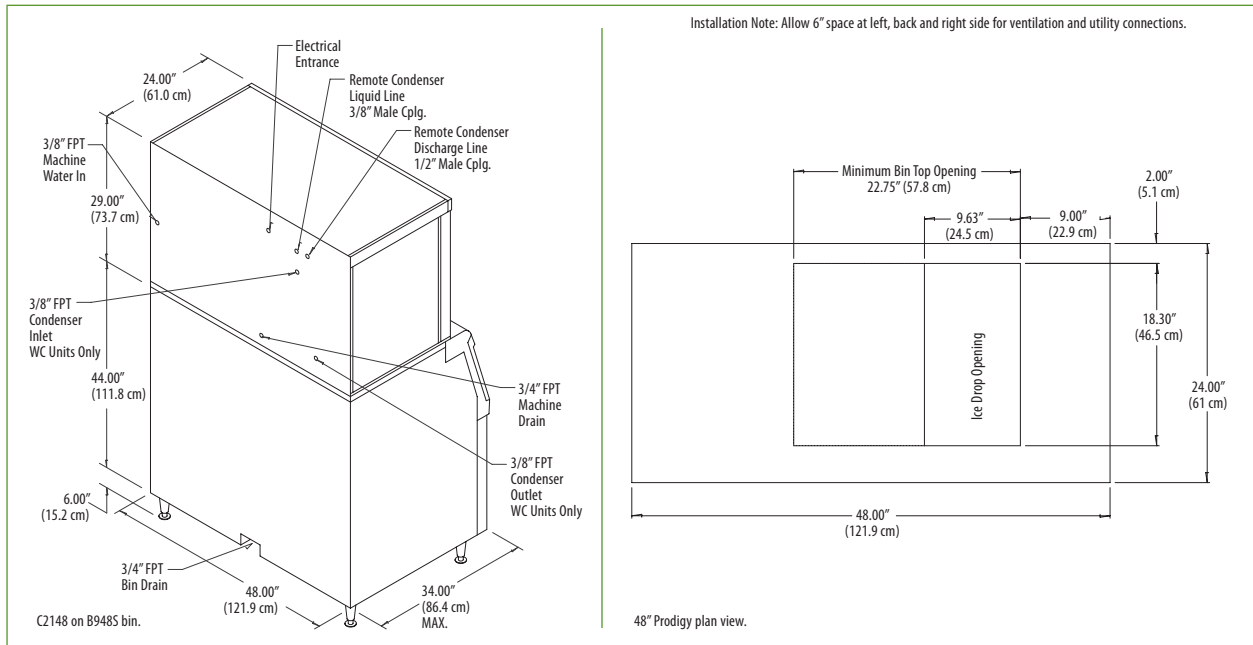

Specifications

Model Number* <small>Cube Size: medium or small</small>	Condenser Unit	Basic Electrical Volts/Hz/Phase	Max. Fuse Size or HACR Circuit Breaker (amps)	Circuit Wires	Min. Circuit Ampacity	Energy Consumption kWh/100 lb (45.4 kg) 90°F(32°C)/70°F(21°C)	Water Usage Gallons/100 lb (liters/45.4 kg)	
							Potable 90°F(32°C)/ 70°F(21°C)	Condenser 90°F(32°C)/ 70°F(21°C)
C2148MR-32	Remote	208-230/60/1	50	2	33.9	4.9	18.2/69.0	-
C2148SR-32	Remote	208-230/60/1	50	2	33.9	4.9	18.2/69.0	-
C2148SR-3	Remote	208-230/60/3	30	3	21.6	4.9	18.2/69.0	-

All Models

Dimensions (W x D x H):
Unit:
48" x 24" x 29"
(121.9 x 61.0 x 73.7 cm)

Shipping Carton:
51.5" x 27.5" x 34"
(130.8 x 69.9 x 86.4 cm)

Shipping Weight:
370 lb / 168 kg

BTUs per hour:
31,600

Accessories

Model Number	Description
KVS	Vari-Smart™ Ice Level Control - Program ice bin levels to match ice needs.
KSBU	Smart-Board™ Advanced Control - Use additional operational data for fast diagnosis.
KSBU-N	Smart-Board™ Advanced Control with Network - Network capable.
ERC611-32	Remote Condenser for C2148xR, 208-230/60/1 - Consult Remote Condenser Spec Sheet for details.
RTE10	Line set, Precharged, R-404A, 10ft.
RTE25	Line set, Precharged, R-404A, 25ft.
RTE40	Line set, Precharged, R-404A, 40ft.
RTE75	Line set, Precharged, R-404A, 75ft.
KPAS	Prodigy Advanced Sustainability kit- Includes KVS and KSBU-N

* Scotsman recommends all ice machines have water filtration. See Scotsman Sanitation Matrix for details.

Operating Requirements

	Minimum	Maximum
Air Temperatures	50°F (10°C)	100°F (38°C)
Water Temperatures	40°F (4.4°C)	100°F (38°C)
Remote Cond. Temps	-20°F (-29°C)	120°F (49°C)
Water Pressures	20 PSIG (1.4 bar)	80 PSIG (5.5 bar)
Electrical Voltage	-5%	+10%

Specifications and design are subject to change without notice.

Scotsman Ice Systems • 775 Corporate Woods Parkway • Vernon Hills, IL 60061

1-800-SCOTSMAN

Fax: 847-913-9844

E-mail: customer.relations@scotsman-ice.com

www.scotsman-ice.com

© 2013 Scotsman Ice Systems.

SIS-SS-PRD-C2148 01-13